

⚠ WARNING

Risk of electrical shock. Disconnect power before servicing or installing luminaire.

⚠ WARNING

Risk of injury or damage. Luminaire will fail if not installed properly. Follow installation instructions.

⚠ WARNING

Risk of injury. Wear safety glasses and gloves during installation and servicing. Allow ample time to cool before handling.

IMPORTANT SAFETY INSTRUCTIONS

- Read all installation instructions before installing. It is important to save these instructions.
- Only install and connect LED module with power disconnected at the circuit breaker. Hot plugging, or connecting the module with power on, could damage the LEDs and is not covered by warranty.
- Observe and follow all label information and instructions regarding dry, damp and wet location listings, proper Intense LED module, warnings of installation near combustible materials and/or insulation.
- Be sure to connect ground wire to prevent electric shock or other potential hazards.
- The product must be installed in a manner consistent with the intended use and in compliance with the national electrical codes and local codes by a person familiar with the construction and operation of the product and the hazards involved.
- **WARNING:** Use only Intense Lighting trims listed for use with this fixture. Use of trims other than those listed by Intense Lighting is a violation of N.E.C 110-3(b) and voids all warranties.

1 FIXTURE HEIGHT CABLE LENGTH ADJUSTMENT

1. Loosen set screw on cable strain relief (do not remove)
2. Adjust to desired cable length
3. Tighten set screw against cable

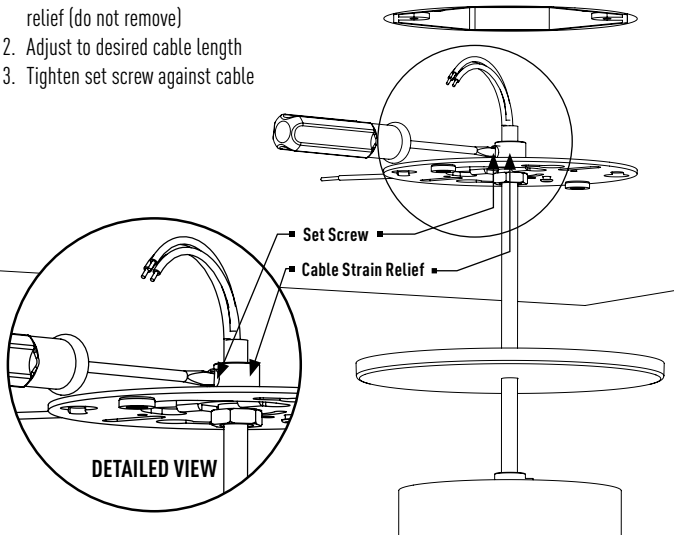

2 ATTACH UNIVERSAL PLATE TO JBOX

1. Two 8-32 fasteners loosely attached to junction box, leave enough space between junction box and fasteners to install universal plate at keyed slots for easier attachment

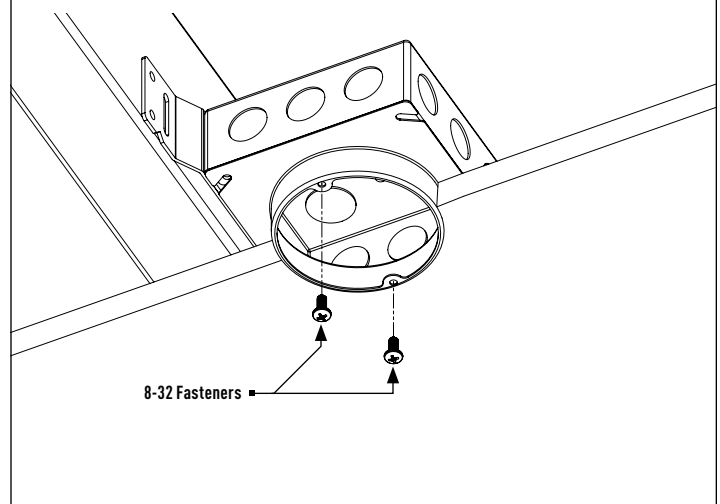

3 ATTACH UNIVERSAL PLATE TO JUNCTION BOX

1. Secure fixture and cable assembly with cable height previously set
2. Make electrical connections
3. Connect ground wire from universal mounting bracket to green (ground) supply wire and ground wire from fixture, white wire from cylinder to red (neutral) supply wire and black wire from cylinder to black (hot) supply wire. Use UL listed connectors or wire nuts (by others) to make the connections. Attach universal mounting plate to junction box using key slots
4. Insure universal plate is flush to ceiling line and free of joint compound and debris, tighten 8-32 fasteners

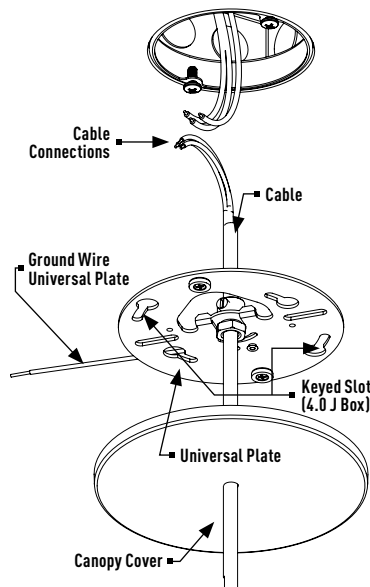

4 CANOPY COVER

1. Make sure all wire connections are pushed into jbox through center clearance area
2. Slide canopy up cable and snap against capture mounting hardware

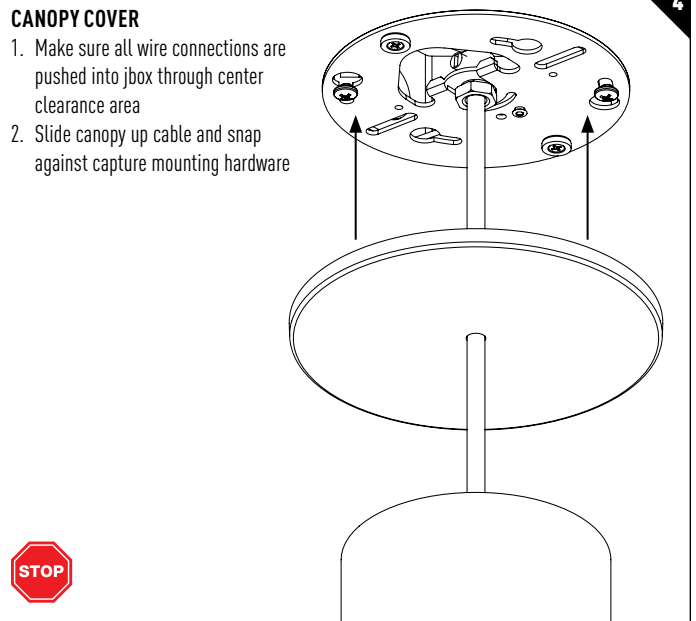

Remote Driver Housing Installation

REMOTE BOX INSTALLATION

1. Attach remote box at two 1/4" holes on 6 inch centers with frame in installation hardware (supplied by others)
2. Remove cover plate
3. Remove required knockouts and run conduit to junction box fixture is attached to (**maximum 50 feet length from fixture**)
4. Run connecting wires for LED driver class 2 by local and national electrical regulations, minimum 18 AWG wire and at maximum 50 feet length
5. Make electrical connections (see wiring diagram at the end of this document)
6. Reinstall cover plate with supplied 8-32 hardware, insure wires are clear of box edges not pinched or damaged when cover is screwed down

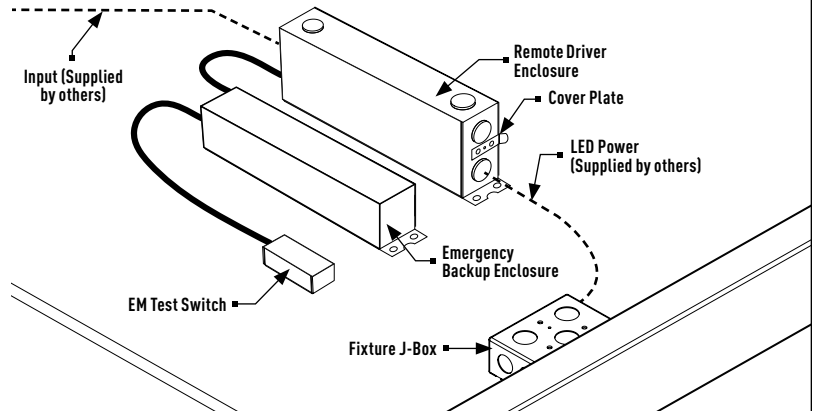

Accessory & Optics Installation

ACCESSORY HOLDER:

1. Rotate release cap by turning counter clockwise.
2. Install accessories into accessory holder and replace accessory holder's retaining clip.
3. Place accessory holder and accessory flush against optic and replace release cap.

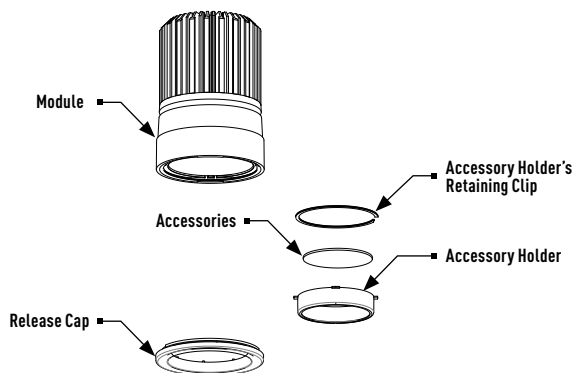

OPTIC REPLACEMENT:

1. Remove trim, then remove module from channel and disconnect quick connect.
2. Rotate release cap by turning counter clockwise.
3. Set cap and retainer ring aside and change optics.
4. Align optic pins to slots in module.

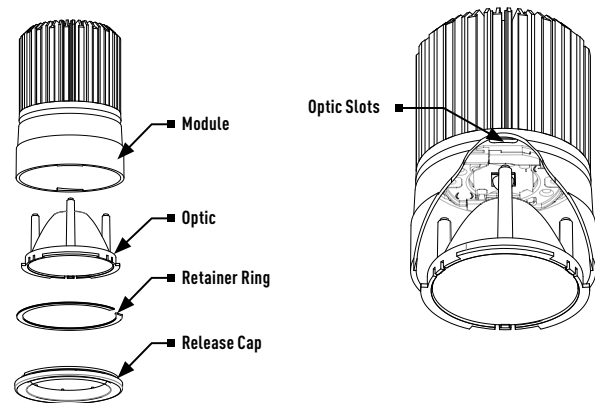

Installation Instructions

3.5" MX Pendant - Dimming Compatibility

IS-C1045R1

3 OF 4

0-10V DIMMING

- 120V/277V
- Dims down to 1% or 0.1% light output
- Consult dimming manufacturer for installation instructions and power packs

COMPATIBLE DIMMERS

Manufacturer	Part Number(s)
HUNT	PS-010-IV-120V, PS-010-WH-120V, PS-010-3W-IV-120, PS-010-3W-WH-120V, PS-010-IV-277V, PS-010-WH-277V, PS-010-3W-IV-277V, PS-010-3W-WH-277V, FD-010: PS-IFC-010-IV, PS-IFC-010-WH-120/277V, FD-010: PS-IFC-010-3W-IV, PS-IFC-010-3W-WH-120/277V, FD-010-120V, FD-010-277V
Leviton	Leviton Centura Fluorescent Control System, IllumaTech™ IP7 Series, DPSPE-212
Lightolier	ZP600FAM120, MP1500FAM120, V2000FAMU
Lithonia	LEQ BC, LEQ LVBC, SLD LVBC, SQ1DC
Lutron	DVTV, NTFTV
Synergy	ISD BC 120/277

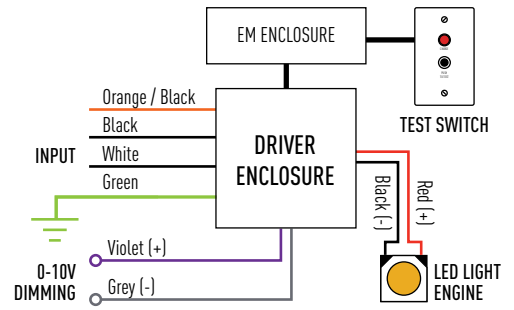

FORWARD / REVERSE PHASE DIMMING

- 120V only
- See chart below for minimum dimming levels
- Consult dimming manufacturer for installation instructions

COMPATIBLE DIMMERS

Product	Part Number(s)	Type	MX MODULE DIMS DOWN TO			
			L0	L1	L2	L3
Leviton	IPED4	Reverse	8%	6%	8%	8%
Leviton	IP106-1LZ	Forward	-	1%	1%	1%
Leviton	6633-P	Forward	1%	1%	1%	-
Lutron	DVELV300P	Reverse	8%	6%	9%	9%
Lutron	DVCL-153P	Forward	1%	1%	1%	1%
Lutron	S600P	Forward	3%	1%	2%	2%
Cooper	DLC03P	Forward	-	1%	1%	2%
Cooper	DAL06P	Forward	-	1%	1%	1%

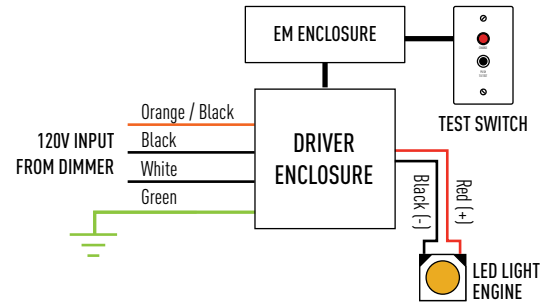

DMX512 RDM DIMMING

- 120V or 277V
- Dims down to 0.1% light output
- RDM channel programmable

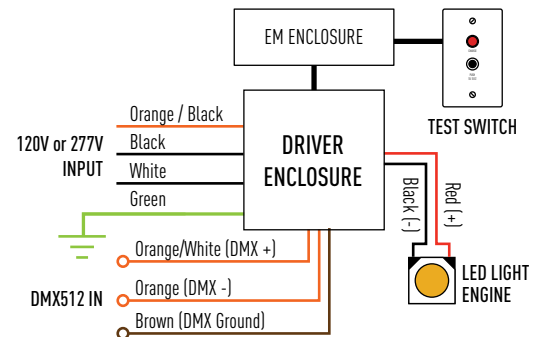

Installation Instructions

3.5" MX Pendant - Dimming Compatibility

IS-C1045R1

4 OF 4

LUTRON ECOSYSTEM® DIMMING

- 120V or 277V
- Dims down to 1%
- Consult dimming manufacturer for installation instructions

COMPATIBLE DIMMERS

Product	Part Number(s)
EcoSystem	CS-1L-WM, CS-2L-WM, CS-1L-CM, CS-2L-CM, EcoSystem ESN, Grafik Eye QS with EcoSystem, Quantum

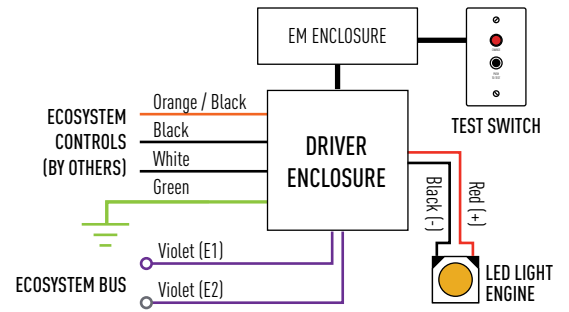

LUTRON HI-LUME® DIMMING

- 120V or 277V
- Dims down to 1%
- Consult dimming manufacturer for installation instructions

COMPATIBLE DIMMERS

AYF-103P, AYF-103P-277, DVF-103, DVF-103P-277, DVSCF-103P, DVSCF-103P-277, HQRD-F6AN-DV, LXF-103PL, LXF-103PL-277, NF-10, NF-103P, NF-103P-277, NF-10-277, NTF-10, NTF-103P, NTF-103P-277, NTF-10-277, RRD-F6AN-DV, SF-12P-277-3, SF-103P, MAF-6AM, MAF-6AM-277, MSCF-6AM, MCSF-6AM-277, MRF2-F6AN-DV, SF-10P, SF-12P-277, SPSF-6A, SPSF-6A-277, SPSF-6AM, SPSF-6AM-277, VF-10, VTF-6AM

