

⚠ WARNING

Risk of electrical shock. Disconnect power before servicing or installing luminaire.

⚠ WARNING

Risk of injury or damage. Luminaire will fail if not installed properly. Follow installation instructions.

⚠ WARNING

Risk of injury. Wear safety glasses and gloves during installation and servicing. Allow ample time to cool before handling.

IMPORTANT SAFETY INSTRUCTIONS

- Read all installation instructions before installing. It is important to save these instructions.
- Only install and connect LED module with power disconnected at the circuit breaker. Hot plugging, or connecting the module with power on, could damage the LEDs and is not covered by warranty.
- Connectors on modules and approved housings are keyed for specific voltage combinations; do not force or attempt to bypass connectors.
- Observe and follow all label information and instructions regarding dry, damp and wet location listings, proper Intense LED module, warnings of installation near combustible materials and/or insulation.
- Turn off power at circuit breaker before attempting to install or perform maintenance on the fixtures.
- Be sure to connect ground wire to prevent electric shock or other potential hazards.
- The product must be installed in a manner consistent with the intended use and in compliance with the national electrical codes and local codes by a person familiar with the construction and operation of the product and the hazards involved.
- Do not block the trim aperture as this may cause unsafe operating conditions.
- **WARNING: RISK OF FIRE.** Non-IC fixture requires that insulation must be kept at least 3" away from all sides of the fixture. Minimum of 90°C supply conductors. Consult a qualified electrician before installation.

WARNING: Use only Intense Lighting trims listed for use with this fixture. Use of trims other than those listed by Intense Lighting is a violation of N.E.C 110-3(B) and voids all warranties.

HOUSING INSTALLATION:

1. Cut out the ceiling hole to 4 1/8" diameter
2. Mount fixture housing according to ceiling type
3. Universal mounting bracket has slot openings for C-channel, flat bar, and 1/2" EMT; secure to joist or grid using fasteners or wire. C-channel hangers are recommended for T-Bar ceilings, install with notches facing down to engage T-Bar grid.

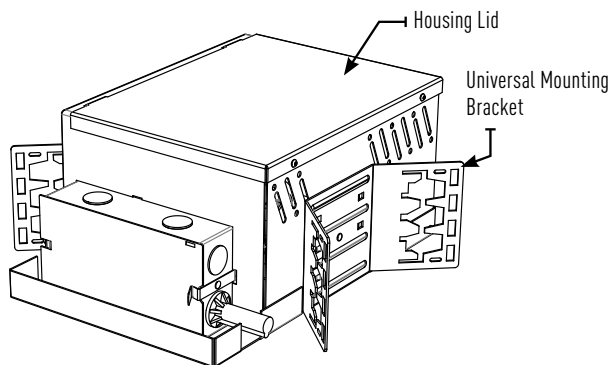

1

MOUNTING:

Bar hanger mounting brackets offer several height choices depending on installation requirements. C-Channel, EMT and other joist bars can be ordered for various ceiling types.

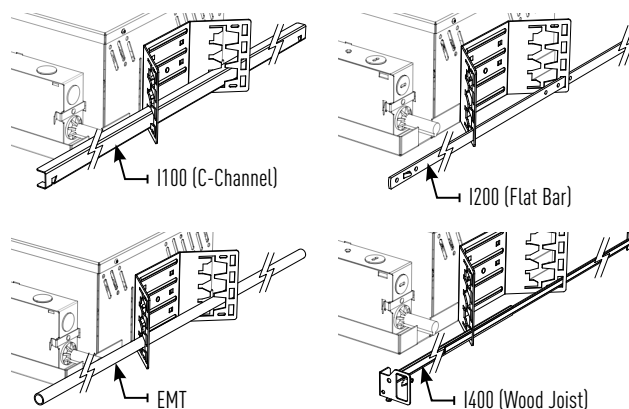

2

WIRING:

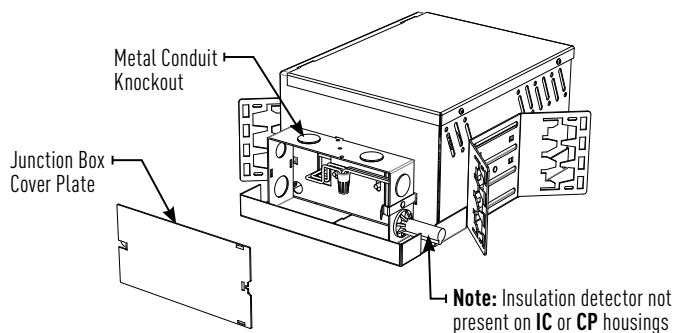

3

ELECTRICAL CONNECTIONS:

1. Make electrical connections through desired knockout for conduit or Romex® cable. Use only UL listed connectors.
2. Connect black wire from fixture to black (HOT) supply wire, white wire from fixture to white (NEUTRAL) supply wire and connect the ground from fixture to green (GROUND) supply wire. Use UL listed connectors or wire nuts to make the connections (provided by others). Connect dimming wires if applicable, see page 4.
3. Close and lock junction box door ensuring all wire connections and wire are contained within.

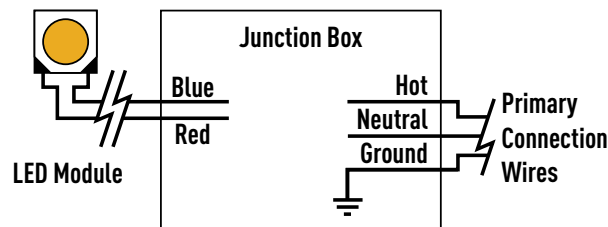

4

HOUSING HEIGHT ADJUSTMENT:

Loosen wingnut to make adjustments so that housing collar is flush with ceiling line.

5

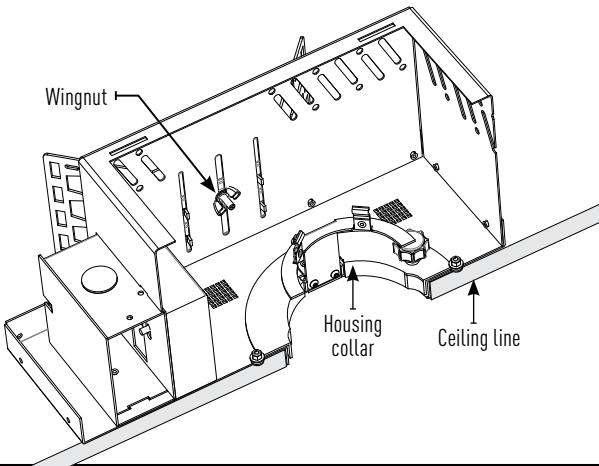

STANDARD CEILING THICKNESS:

For specific mounting requirements, see submittal spec sheet.

6A

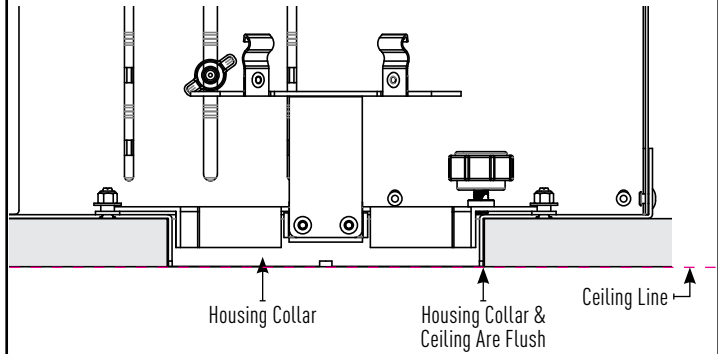

WOOD CEILING THICKNESS INSTALL

1. Ceiling thicknesses over 5/8" require custom spring clips on trim. For specific mounting requirements, see submittal spec sheet.
2. For wood ceiling applications, housings collar needs to be 1/8" from the ceiling line so the trim can properly sit in the housing.

6B

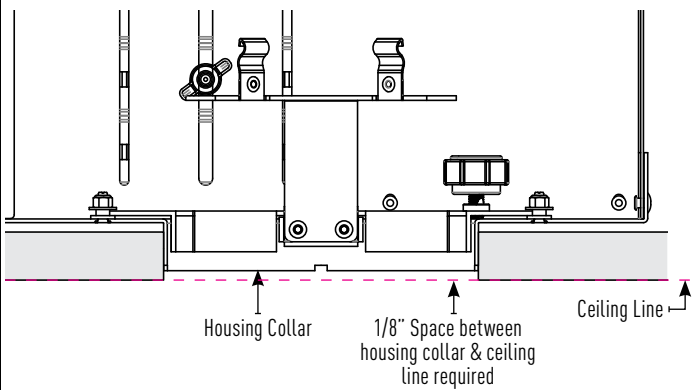

TRIMLESS INSTALLATION:

1. Align perforated mud plate to notches on the housing and insert fully into the housing.
2. Once the perforated mud plate is fully inserted, secure the perforated mud plate to housing with #8 drywall screws (by others).
3. Reinstall plenum cover to prevent paint damage to fixtures.
4. Apply joint compound over perforated mud plate and feather out accordingly.

7A

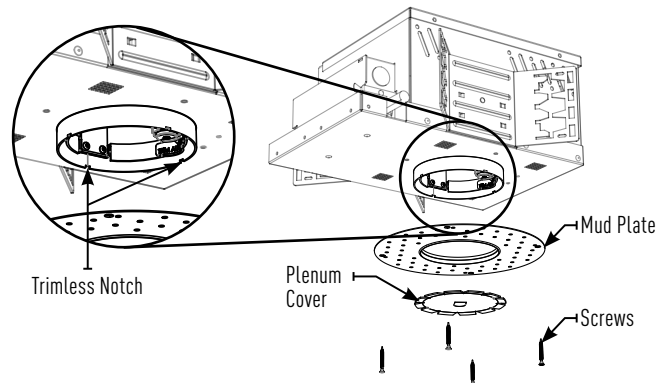

TRIMLESS INSTALLATION:

1. Screw in mud plate into drywall.

Note: Do not remove plenum cover until mud and paint has been applied

7B

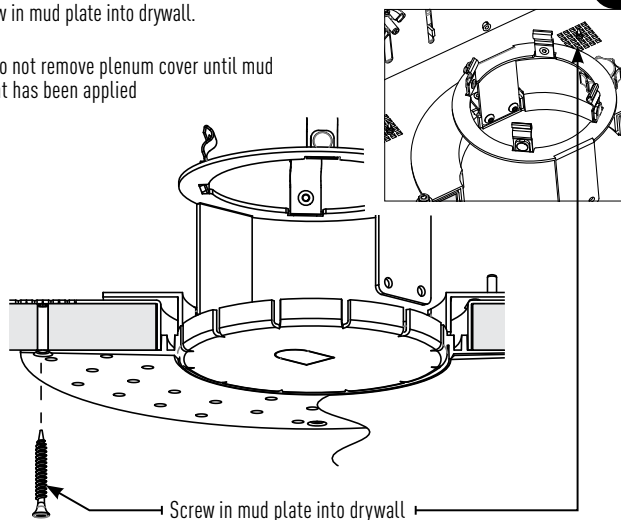

MODULE INSTALLATION:

1. Ensure bracket is at a 0° angle.
2. Check that power is off at breaker, hot plugging may damage LEDs.
3. Connect female quick connect from housing to male quick connect on module.
4. Snap module into channel and confirm module sits parallel to ceiling line and is securely fastened into housing.

8

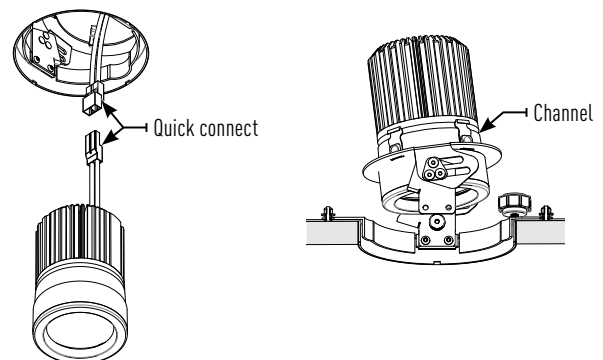

ADJUSTING HORIZONTAL ADJUSTMENT:

1. Loosen thumb screw to allow fixture to adjust horizontally.
2. Place philips screw driver into adjustment assist to rotate module to desired horizontal position. (Trim alignment sticker must be pointed to wall)
3. Tighten thumb screw to lock horizontal rotation.

9

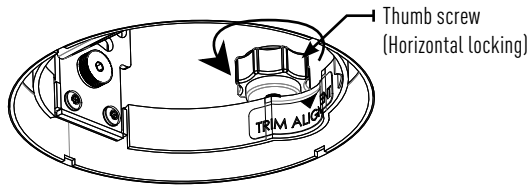

ADJUSTING WALL WASH POSITION:

1. Loosen knurled head thumb screw to allow fixture to slide into position.
2. Slide wall wash module and bracket away from trim location label.
3. Tighten knurled head thumb screw to lock wall wash position, by hand or with 2.5mm hex key.

10

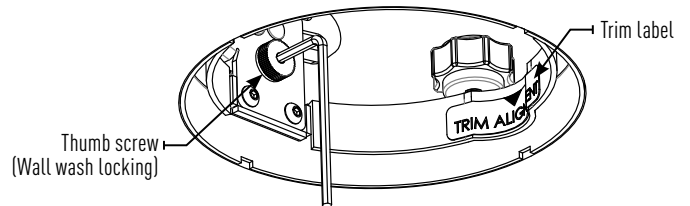

TRIM INSTALLATION (APPLIES TO ROUND HOUSING ONLY):

1. Position trim alignment label to trim location label on the housing collar.
2. Snap trim into the housing.
3. Luminaire will direct wall washing light in the direction of the trim alignment label.

11A

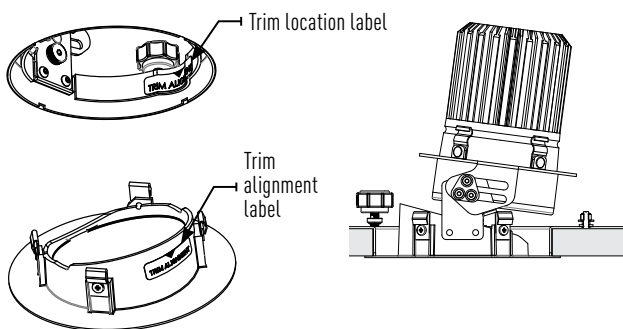

TRIM INSTALLATION (APPLIES TO SQUARE HOUSING ONLY):

1. Position trim alignment label to trim location label on the housing collar.
2. To install trim, rotation plate must be parallel with the housing. Note: Trim will not lineup at any other angle than 90° increments.

11B

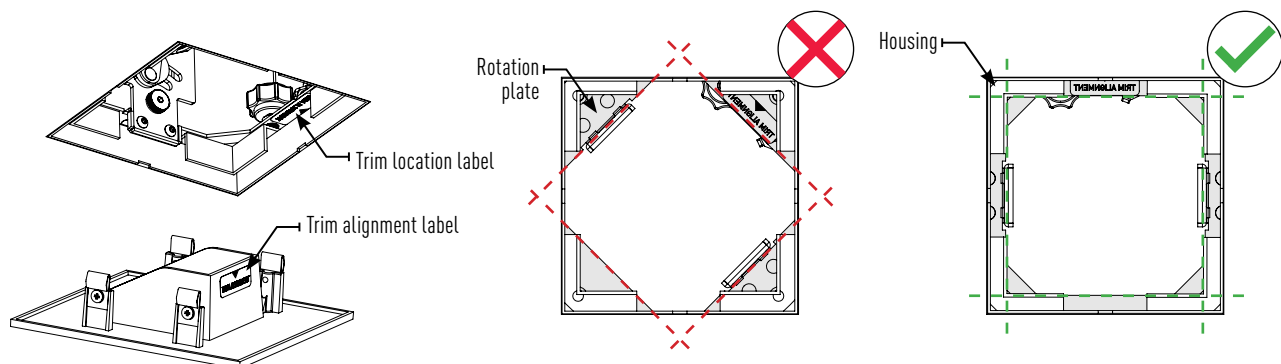

DRIVER REPLACEMENT:

1. Adjust wall wash assembly by pulling forward to assure clearance.
2. Unscrew all four 2mm allen key head machine screws on both sides.
3. Remove vertical adjustment assembly by tilting the assembly to assure clearance.
4. Unsnap driver plate from junction box. Disconnect quick connect from driver plate and input quick connect.
5. Guide driver/driver plate/module quick connect through opening.
6. Replace new driver on driver plate and replace module quick connect. (**Note:** Ensure wall wash bracket is reinstall as original orientation)

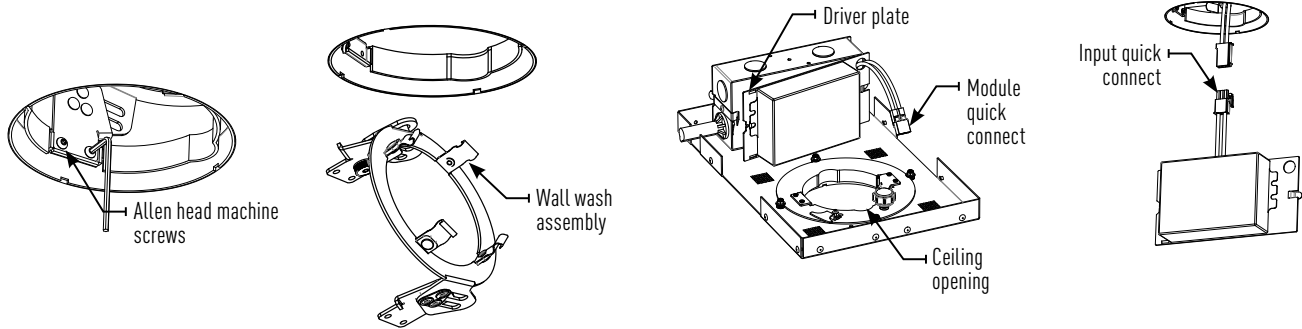

ACCESSORY HOLDER:

1. Rotate release cap by turning counter clockwise.
2. Install accessories into accessory holder and replace accessory holder's retaining clip.
3. Place accessory holder and accessory flush against optic and replace release cap.

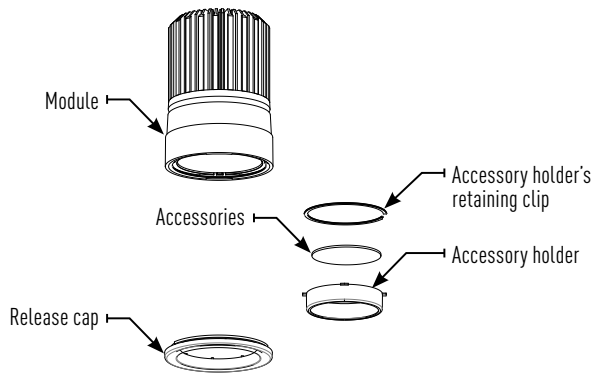

OPTIC REPLACEMENT:

1. Remove trim, then remove module from channel and disconnect quick connect.
2. Rotate release cap by turning counter clockwise.
3. Set cap and retainer ring aside and change optics.
4. Align optic pins to slots in module.

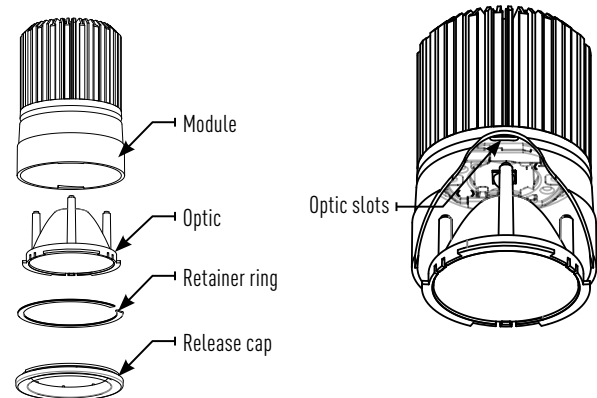

WIRING & DIMMING COMPATIBILITY

For use with all Intense Lighting product with supported dimming options.
Please check configuration of product for correct dimming protocol.

Phase Dimming or Lutron® LTEA2W Hi-Lume 2-Wire

- 120V Only
- Forward 1% / Reverse 5%

COMPATIBLE DIMMERS

Product	Part Number(s)	Type
Leviton	IPE04	Reverse
Leviton	IPI06-1LZ	Forward
Leviton	6633-P	Forward
Lutron	DVELV300P	Reverse
Lutron	DVCL-153P	Forward
Lutron	S600P	Forward
Cooper	DLC03P	Forward
Cooper	DAL06P	Forward

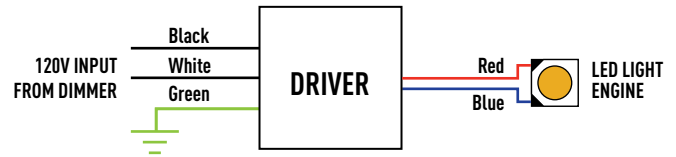

0-10V Dimming

- 120V or 277V
- Dims down to 1% or 0.1% light output
- Consult dimming manufacturer for installation instructions and power packs

COMPATIBLE DIMMERS

Manufacturer	Part Number(s)
HUNT	PS-010-IV-120V, PS-010-WH-120V, PS-010-3W-IV-120, PS-010-3W-WH-120V, PS-010-IV-277V, PS-010-WH-277V, PS-010-3W-IV-277V, PS-010-3W-WH-277V, FD-010: PS-IFC-010-IV, PS-IFC-010-WH-120/277V, FD-010: PS-IFC-010-3W-IV, PS-IFC-010-3W-WH-120/277V, FD-010-120V, FD-010-277V
Leviton	Leviton Centura Fluorescent Control System, IlLumaTech™ IP7 Series, DPSPE-212
Lightotier	ZP600FAM120, MP1500FAM120, V2000FAMU
Lithonia	LEQ BC, LEQ LVBC, SLD LVBC, SQ1DC
Lutron	DVTV, NTFTV
Synergy	ISD BC 120/277

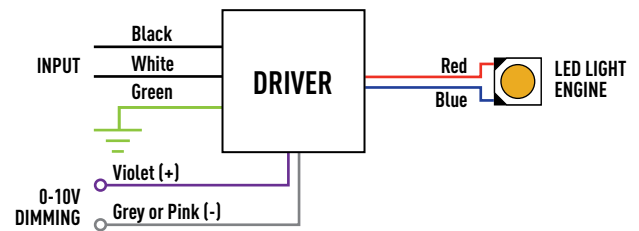

Lutron® LDE1 Hi-Lume EcoSystem

- 120V or 277V
- Dims down to 1%
- Consult dimming manufacturer for installation instructions

COMPATIBLE DIMMERS

Product	Part Number(s)
EcoSystem	CS-1L-WM, CS-2L-WM, CS-1L-CM, CS-2L-CM, EcoSystem ESN, Grafik Eye QS with EcoSystem, Quantum

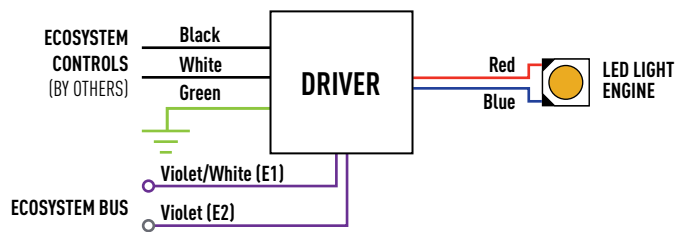

DMX512 RDM (Downlights with RJ45)

- 120V or 277V
- Dims Down to 0.1% Light Output
- RDM Channel Programmable

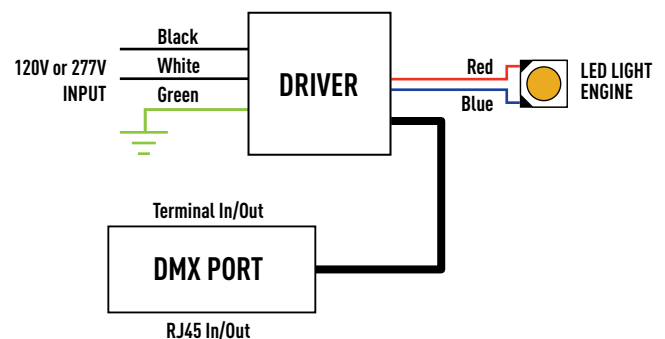

WIRING & DIMMING COMPATIBILITY

For use with all Intense Lighting product with supported dimming options.
Please check configuration of product for correct dimming protocol.

DMX512 RDM (Cylinders without RJ45)

- 120V or 277V
- Dims Down to 0.1% Light Output
- RDM Channel Programmable

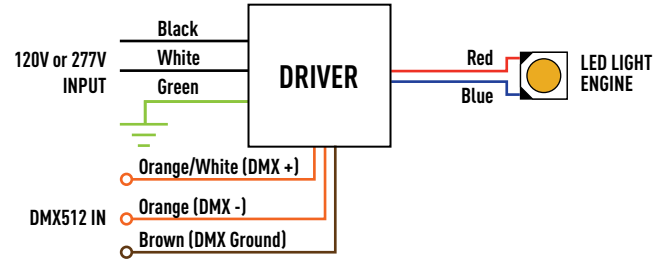

0-10V With Dynamic Beam

- 120V or 277V
- Dims down to 1% or 0.1% light output
- Consult dimming manufacturer for installation instructions and power packs

COMPATIBLE DIMMERS

Manufacturer	Part Number(s)
HUNT	PS-010-IV-120V, PS-010-WH-120V, PS-010-3W-IV-120, PS-010-3W-WH-120V, PS-010-IV-277V, PS-010-WH-277V, PS-010-3W-IV-277V, PS-010-3W-WH-277V, FD-010: PS-IFC-010-IV, PS-IFC-010-WH-120/277V, FD-010: PS-IFC-010-3W-IV, PS-IFC-010-3W-WH-120/277V, FD-010-120V, FD-010-277V
Leviton	Leviton Centura Fluorescent Control System, IllumaTech™ IP7 Series, DPSPE-212
Lightolier	ZP600FAM120, MP1500FAM120, V2000FAMU
Lithonia	LEQ BC, LEQ LVBC, SLD LVBC, SQ1DC
Lutron	DVTV, NTFTV
Synergy	ISD BC 120/277

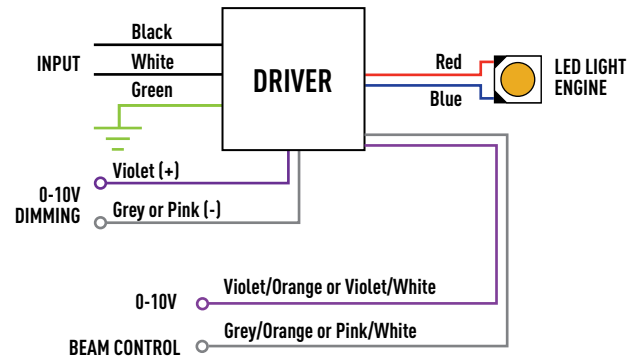

0-10V With Tunable White

- 120V or 277V
- Dims down to 1% or 0.1% light output
- Consult dimming manufacturer for installation instructions and power packs

COMPATIBLE DIMMERS

Manufacturer	Part Number(s)
HUNT	PS-010-IV-120V, PS-010-WH-120V, PS-010-3W-IV-120, PS-010-3W-WH-120V, PS-010-IV-277V, PS-010-WH-277V, PS-010-3W-IV-277V, PS-010-3W-WH-277V, FD-010: PS-IFC-010-IV, PS-IFC-010-WH-120/277V, FD-010: PS-IFC-010-3W-IV, PS-IFC-010-3W-WH-120/277V, FD-010-120V, FD-010-277V
Leviton	Leviton Centura Fluorescent Control System, IllumaTech™ IP7 Series, DPSPE-212
Lightolier	ZP600FAM120, MP1500FAM120, V2000FAMU
Lithonia	LEQ BC, LEQ LVBC, SLD LVBC, SQ1DC
Lutron	DVTV, NTFTV
Synergy	ISD BC 120/277

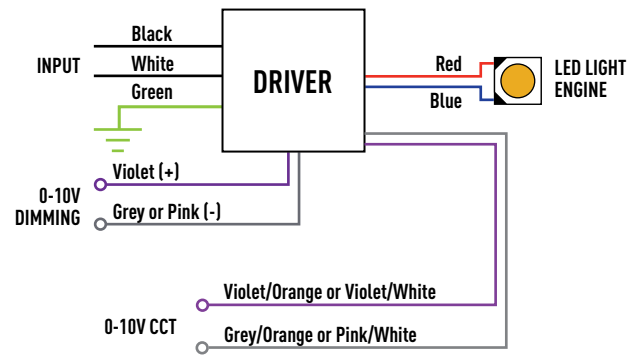

DALI With Tunable White

- 120V or 277V
- Dims down to 0.1%

